

# MOTIV™ SU

AsahiKASEI  
BIOPROCESS

## Buffer Innovation In A Single-Use Package

The single-use extension of our award-winning line of MOTIV inline buffer formulation systems is built to produce complex buffers on-demand effectively and efficiently – all from one pump head, and without the need for CIP/SIP procedures between batches. The innovative design modulates flow through control valves while simultaneously integrating buffer solutions, providing proportional flow control, and mixing. As with all our MOTIV systems, OCELOT System Control ensures precise blends every time, controlled by pH and conductivity feedback or flow.



### MOTIV SU

24 - 2400 L/h

Mobile console format

Clinical scale manufacturing

Up to 20X dilution

58.22" L x 32" W x 63.27" H

Note: Dimensions are approximate.  
Customized systems for unique applications are also available.

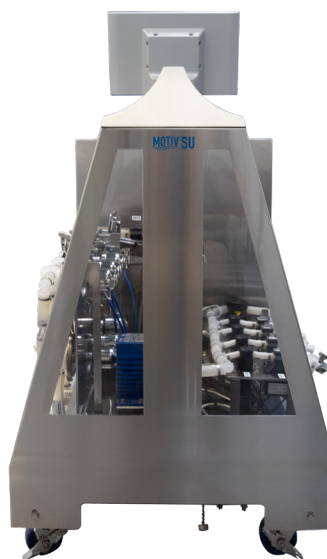

[REQUEST A QUOTE >](#)

# MOTIV™ SU

AsahiKASEI  
BIOPROCESS



powered by  
**OCELOT**  
SYSTEM CONTROL

Sensors: F = Flow Rate    C = Conductivity    pH

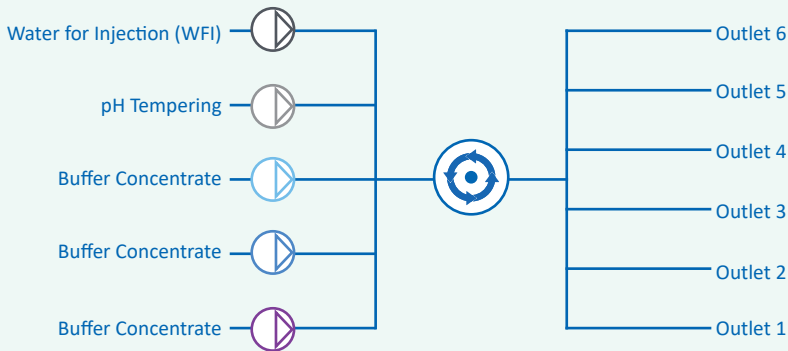

Achieve constant, controlled flow rates  
from all incoming process streams

+/- 0.5 mS/cm or better

+/- 0.2 pH or better

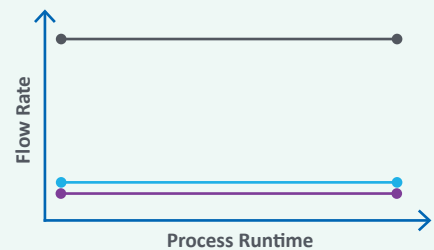

## Contact Us

Asahi Kasei Bioprocess America, Inc.

Technical Client Services

+1 833-HLP-AKBA (457-2522)

TCS.support@ak-bio.com

www.ak-bio.com

