

THESYS™ C&D

THESYS™ Cleavage and Deprotection Systems

*Thoughtfully designed to enhance
production safety and efficiency*



Built For You.

Our mid- to large-scale THESYS™ C&D Systems allow you to automate the cleavage and deprotection steps while increasing productivity by freeing up your oligosynthesizer to focus on its core job of synthesis.

Solid phase synthesis using flow-through columns has become the proven method for reliably producing antisense, RNAi and other therapeutic oligonucleotides by manufacturers. After synthesis, the oligo must be cleaved from the solid support and conditioned for further downstream processing.

To streamline and automate this overlooked unit operation, Asahi Kasei Bioprocess offers a family of THESYS Cleavage and Deprotection (C&D) Systems for your clinical- and commercial-scale oligonucleotide manufacturing needs.

Available in flow rates starting at 180 L/h up to 2000 L/h, THESYS C&D Systems are designed to accommodate both DNA and RNA processes.



*The **only** large-scale, automated cleavage and deprotection system.*

Synthesis

Cleavage and Deprotection

Purification

Concentration

Lyophilization

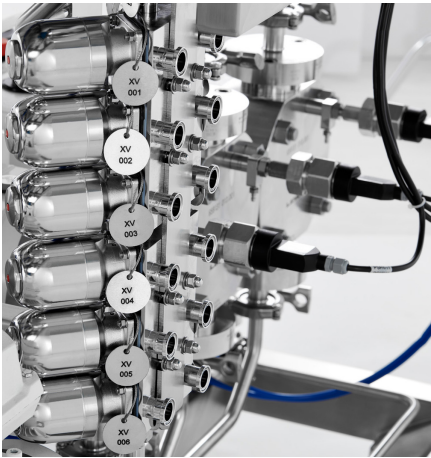

Automate Your Total Oligo Manufacturing Process

The manufacture of therapeutic oligonucleotides is a chemical process. Synthesis, purification, concentration and lyophilization steps have all been automated with software-controlled systems validated for GMP manufacturing. Yet liberating the oligonucleotide from the column post-synthesis has been left to manual processing or done with repurposed equipment. After cleavage, the deprotection step of heating the dissolved oligonucleotides has typically been conducted manually in a stand-alone vessel. Now, a fully automated system to manage both cleavage and deprotection is available, ensuring efficiency for your entire manufacturing process.

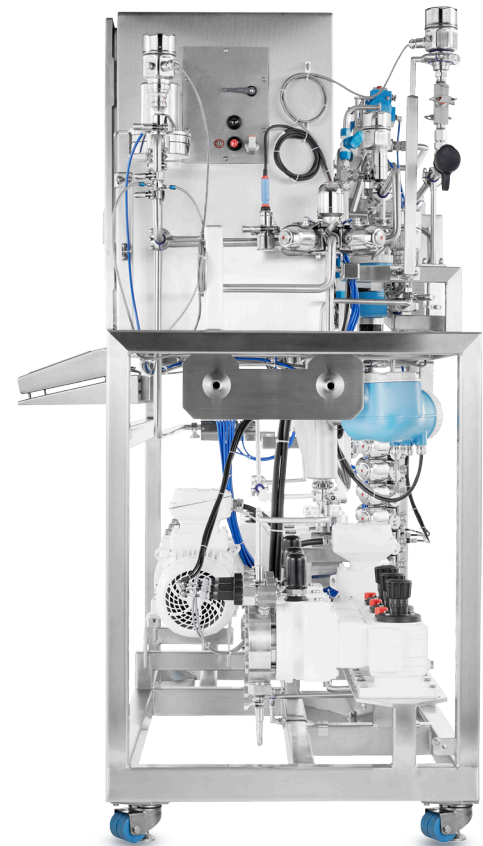

Available in flow rates starting at 180 L/h up to 2000 L/h, THESYS C&D Systems are designed to accommodate both DNA and RNA processes.

Analysis Made Easy

The THESYS™ C&D System includes our industry-leading software – OCELOT™ – enabling powerful and intuitive in-process controls to automate the cleavage and deprotection steps. Built to be OPC-ready, OCELOT can also integrate and/or interface with your plant-wide control system, allowing for far-reaching data collection and analysis.

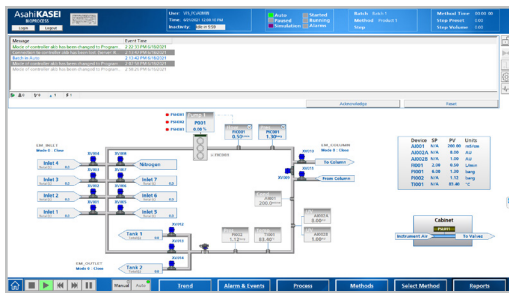

Process Control Screen

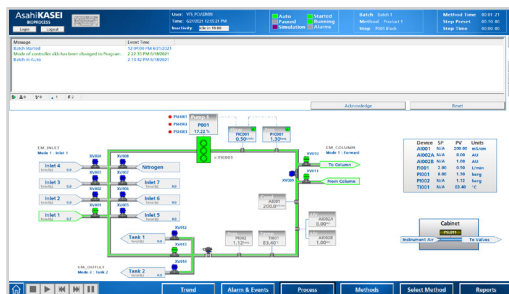

Process Control Screen during a batch

Features:

- » Universal Run Phase for washing, liberation and deprotection steps
- » Universal Wait Phase for reaction watching and hold steps
- » End conditions
- » Alarms and interlocks
- » 21 CFR Part 11 compliant control software
- » Audit trail and electronic signature
- » Customizable batch reports
- » Data export
- » OPC compatibility
- » Optional control of external vessel mixer and external temperature control units

Universal Run Phase

Pumps are monitored and controlled by independent Coriolis mass flowmeters to ensure that both the flow rate and the total volume delivery is consistent with programmed set points.

End conditions can be triggered by time, volume, column volume, conductivity or UV signals.

This phase can be configured for column washing, oligonucleotide liberation and base deprotection additions.

Universal Wait Phase

Pumps are not running but other in-process controls such as timers, temperature and analytical monitors are active.

This configurable phase is ideal for reaction watching and other process hold steps.

powered by **OCELOT™**
SYSTEM CONTROL

Flexible for DNA and RNA

The THESYS™ C&D System includes a multi-port inlet manifold and a delivery pump to dose the necessary chemicals and reagents to your column for cleavage and subsequently to your deprotection vessel. The unit also includes inline monitoring of temperature, conductivity and UV.

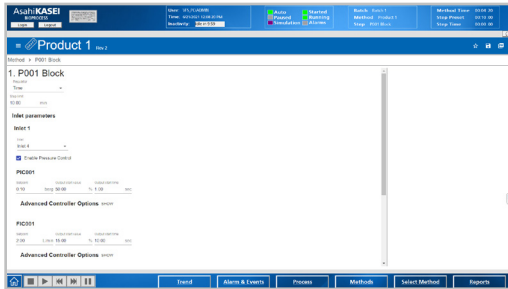

Inlet parameter and advanced controller options

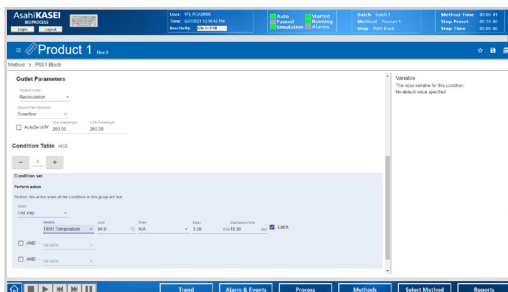

Outlet parameters and condition table that shows an end step for temperature.



Standard THESYS C&D System includes:

- » Eight (8) main inlet ports
- » Hygienic triplex diaphragm pump for chemical metering
- » Pressure relief valve
- » Coriolis flowmeter for flow control and totalization
- » Column forward flow and bypass modes
- » Pre- and post-column pressure sensors
- » Post-column conductivity monitoring
- » Post-column multiple wavelength UV monitoring
- » Post-column temperature monitoring
- » Backpressure regulation
- » Three (3) outlet ports including recirculation
- » Electropolished 316L SS construction
- » Tri-Clamp® connections throughout
- » Hazardous area rating:
 - » NFPA Class 1, Div. 2, Groups C & D
 - » ATEX II Category 3, IECEx Zone 2

For deprotection of RNA oligonucleotides which require a fluoride ion source, THESYS C&D Systems can optionally be supplied with a second dosing pump and flowmeter constructed of Hastelloy for chemical compatibility.

Due to the wide range of volume requirements for processes, a jacketed vessel where dissolved oligonucleotides are held during heating and deprotection is not included. Use an existing vessel, or one can optionally be supplied as part of the THESYS C&D System package.

Please contact your Account Manager for details.

Documentation for THESYS™ C&D Systems

To support your clinical and commercial cGMP manufacturing needs, all THESYS C&D Systems are provided with a GMP documentation package that includes the following:

- » User manual
- » Pressure test certificate
- » Spare parts list
- » Material certificates for wetted surfaces
- » Certificates of calibration for instruments
- » USP Class VI certificates for wetted seals
- » BSE/TSE-free certificates for product contact seals
- » Certificate of 21 CFR Part 11 capability
- » Optional IQ/OQ protocol generation and execution
- » Optional GAMP-5 lifecycle documentation



Standardized design with options for flexibility

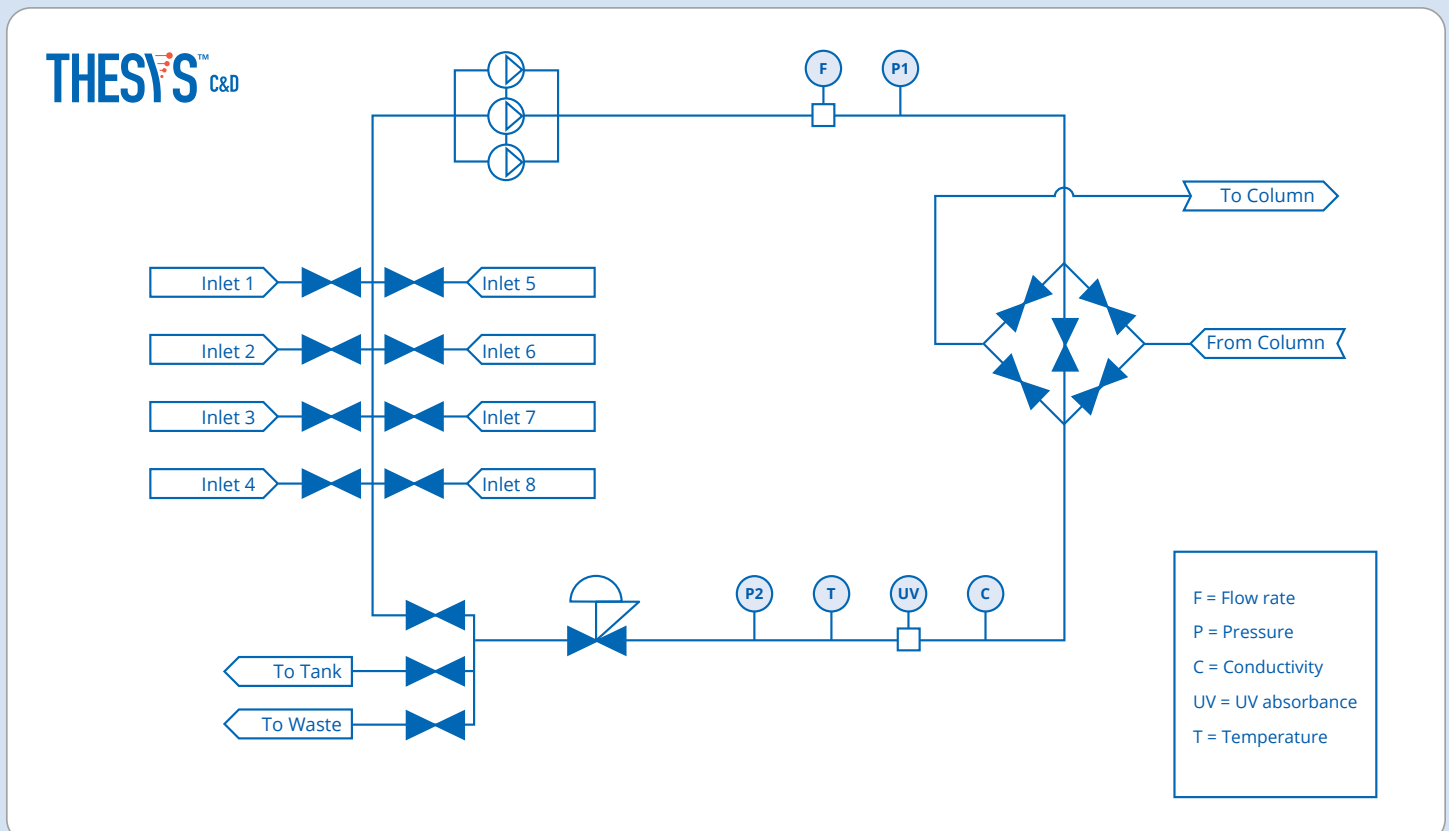

Customizable Options

C&D Systems can be customized to meet specific user requirements for your manufacturing process:

- » Second metering pump and flowmeter constructed of Hastelloy
- » Upgrade from eight (8) to twelve (12) main inlet ports
- » Jacketed deprotection vessel (user-specified volume)
- » Upgrade from three (3) to four (4) outlet ports including recirculation
- » Local panel-mount Human-Machine Interface (HMI)



Ordering Information

| Catalog No. | Deprotection Vessel Working Volume | Pressure Rating | Metering Pump Flow Rate | Material of Construction |
|-------------|------------------------------------|-----------------|-------------------------|--------------------------|
| CD020 | 20 L | 6 bar | 6 to 180 L/h | 316L SS |
| CD100 | 100 L | 6 bar | 20 to 600 L/h | 316L SS |
| CD350 | 350 L | 6 bar | 48 to 2000 L/h | 316L SS |

Note: This product may be subject to export control



Aftermarket Services

Technical Support Network

A reliable technical support network is available throughout North and South America, Europe and Asia.

Warranty

We offer an extendable 1-year warranty, service contracts and a personalized level of service for peace of mind and timely support when you need it.

[REQUEST A QUOTE >](#)

Technical Client Services

Technical Client Services (TCS), is a customer-centric interface to our product and science experts. Our TCS team will guide your process and engineering needs as your personal liaison for inquiries. Contact us to learn more about how TCS can support your virus filtration and downstream processing equipment needs.

Asahi Kasei Bioprocess America, Inc.

Technical Client Services

+1 833-HLP-AKBA (457-2522)

TCS.support@ak-bio.com

www.ak-bio.com

Global Offices

North and South America

Glenview, IL, USA
Tel: +1-833-457-2522
Fax: +1-847-556-9701

Email: info.us@ak-bio.com

Europe

Cologne, Germany
Tel: +49-221-995007-59
Fax: +49-221-9950077-59

Email: info.eu@ak-bio.com

India and Southeast Asia

Mumbai, India
Tel: +91-22-6710-3962
Fax: +91-22-6710-3979

Email: info.jp@ak-bio.com

East Asia and Oceania

Glenview, IL, USA
Tel: +1-833-457-2522
Fax: +1-847-556-9701

Email: info.jp@ak-bio.com

China

Shanghai, China
Tel: +86-(0)21-6391-6111
Fax: +86-(0)21-6391-6686

Email: info.jp@ak-bio.com