

Making the Complex Simple

Our 5-pump inline buffer formulation systems can produce more complex buffers constructed from up to five streams. Our systems provide the ultimate flexibility to generate mixtures using a combination of conductivity, pH and mass flow control. As with all of our inline buffer systems, OCELOT™ System Control will automate the process to ensure accuracy and repeatability.

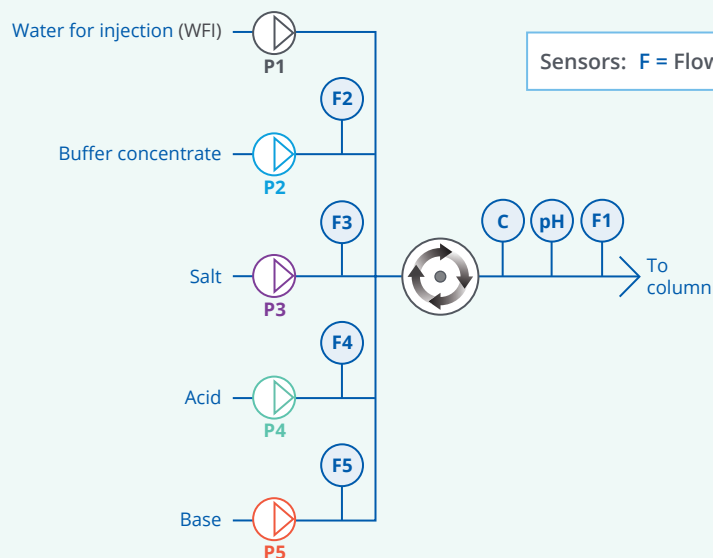

Sensors: F = Flow rate C = Conductivity pH

Conductivity and pH control / Flow control
 +/- 0.1 mS/cm or better
 +/- 0.1 pH or better



MOTIV 510	MOTIV 512	MOTIV 525	MOTIV 550
60 – 1000 L/h	120 – 1200 L/h	Up to 2500 L/h	500 – 5000 L/h
Mobile console format	Space-saving skid format	Space-saving skid format	Space-saving skid format
Clinical scale manufacturing	Large scale manufacturing	Large scale manufacturing	Large scale manufacturing
Up to 20x dilution	Up to 20x dilution	Up to 20x dilution	Up to 20x dilution
1530mm x 1070mm x 1830mm	1530mm x 1070mm x 1830mm	1800mm x 762mm x 1854mm	Custom

Note: Dimensions are approximate. Customized systems for unique applications are also available.

[REQUEST A QUOTE >](#)