

MOTIV[®]

Inline Buffer Formulation Systems

Exceeding expectations with an industry-leading range

Built For You.

Creating safe, affordable biologics today requires increased buffer production. Asahi Kasei Bioprocess is dedicated to unlocking efficiencies and driving buffer productivity in your biopharmaceutical downstream processing area.

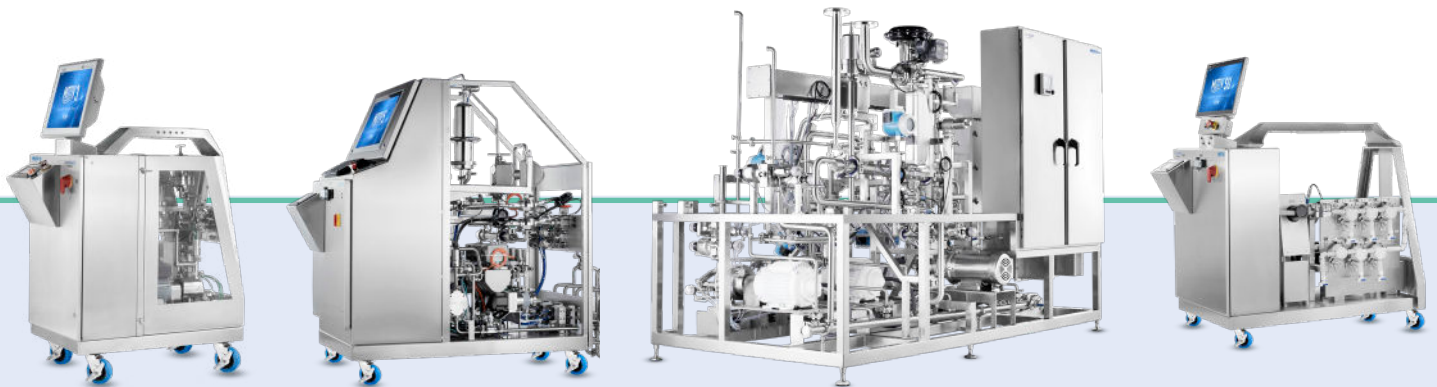

MOTIV[®] 3

MOTIV[®] 5

MOTIV[®] plus

MOTIV[®] SU

You can move beyond downstream bottlenecks with MOTIV[™]: our line of industry-leading inline buffer formulation systems available in standard and custom configurations to give you confidence in achieving a consistent, precise yield every time.

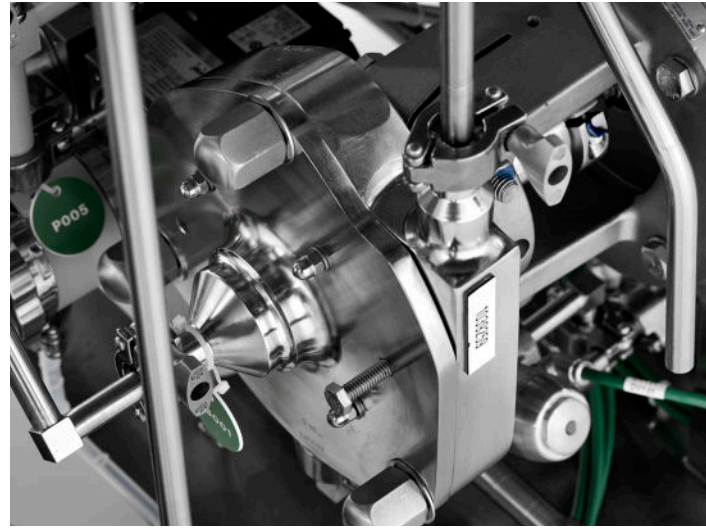
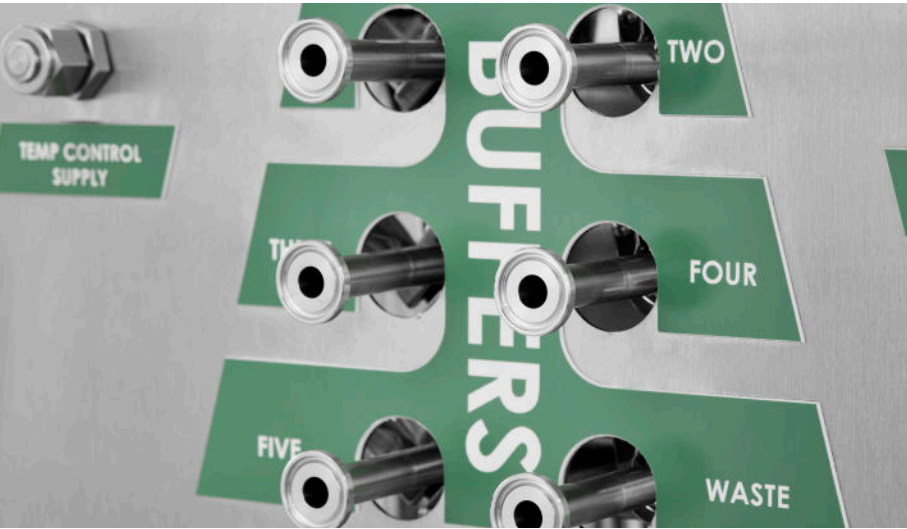

Accurate and Reproducible Buffer Formulation

Whether your production plant is a stainless steel or compatible alloys fed-batch facility or a single-use perfusion facility, your downstream processes demand large volumes of dilute and often complex buffers. Thousands of liters can be required for protein capture, polishing, concentration and virus removal, with very specific compositions required at each step.

MOTIV™ Inline Buffer Formulation Systems are trusted for cost-effective just-in-time preparation of millions of liters of dilute and pH-conditioned buffers from up to 20X stock concentrates in cGMP production facilities around the world.

Built upon our patented Pro-Yield™ inline recirculation blender technology, our family of 3-pump, 5-pump and custom inline buffer formulation systems can meet almost any space, cost or performance need.



Our award-winning technology continues to set the industry standard — staying at the forefront, and always with the future in mind.

Pro-Yield™ Recirculation Blender Technology

Our patented dynamic recirculation blender built into every stainless-steel MOTIV™ dramatically improves the buffer response rate, allowing all systems to reach their target setpoints within seconds.

Features:

- » Highly efficient mixing regardless of flow rate or viscosity
- » Increases pH adjustment precision
- » Single pass mixing – faster to setpoint, smaller washout volumes



Buffer preparation comparison

Consideration	Manual Batch Compounding	MOTIV™
<i>Buffer prep footprint</i>	Large	Small (less than half)
<i>Mode of operation</i>	Labor-intensive	Automated
<i>Production switchover time from Buffer A to Buffer B</i>	Hours	Minutes
<i>Final conductivity and pH accuracy and precision</i>	Relatively low	High
<i>Buffer preparation time</i>	Produced and released in hours	Produced and released in seconds
<i>Regulatory acceptance</i>	Used in cGMP manufacturing facilities	Used in cGMP manufacturing facilities
<i>Reproducible dilution and conditioning</i>	No	Yes
<i>Suitable for continuous processes</i>	No	Yes
<i>Suitable for batch processes</i>	Yes	Yes
<i>Ancillary equipment required</i>	Requires large capital investment of stainless steel tanks	Can be used with single-use bags
<i>Impact on improved protein recovery</i>	Low	High

Straight-Forward Buffer Formulation

Our 3-pump inline buffer formulation systems provide dilute and conditioned buffers constructed from up to three streams. One larger pump is used to deliver the diluent, typically WFI or purified water, into the system. And two smaller pumps can deliver buffer concentrate and an acid or base modifier, respectively. The built-in automation software – OCELOT™ System Control – can near-effortlessly regulate the blend to exact specifications using conductivity and pH feedback control, or alternatively mass flow control.

Sensors: **F** = Flow rate **C** = Conductivity **pH**

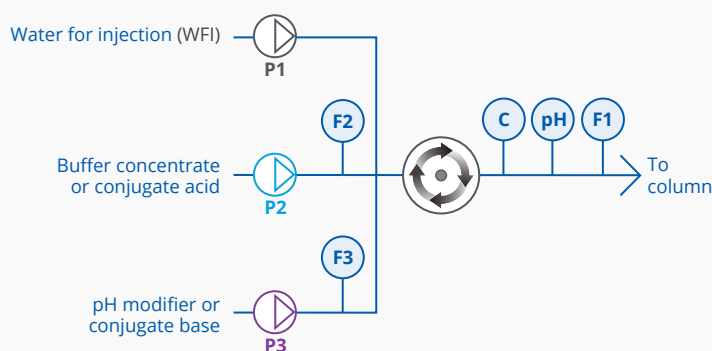

Achieve constant, controlled flow rates from all incoming process streams

+/- 0.1 mS/cm or better

+/- 0.1 pH or better

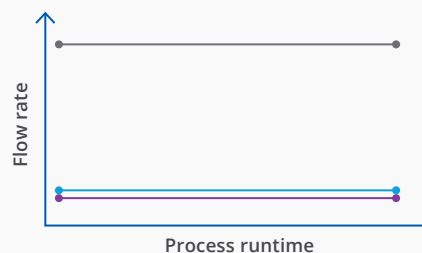

MOTIV 310	MOTIV 312	MOTIV 325	MOTIV 350
60 – 1000 L/h	120— 1200 L/h	Up to 2500 L/h	500 – 5000 L/h
Mobile console format	Space-saving skid format	Space-saving skid format	Space-saving skid format
Clinical scale manufacturing	Large scale manufacturing	Large scale manufacturing	Large-scale manufacturing
Up to 20x dilution	Up to 20x dilution	Up to 20x dilutio	Up to 20x dilution
770mm x 1500mm x 1610mm	770mm x 1500mm x 1610mm	1370mm x 762mm x 1854mm	1990mm x 1220mm x 1880mm

Note: Dimensions are approximate. Customized systems for unique applications are also available.

Making the Complex Simple

Our 5-pump inline buffer formulation systems can produce more complex buffers constructed from up to five streams. Our systems provide the ultimate flexibility to generate mixtures using a combination of conductivity, pH and mass flow control. As with all of our inline buffer systems, OCELOT™ System Control will automate the process to ensure accuracy and repeatability.

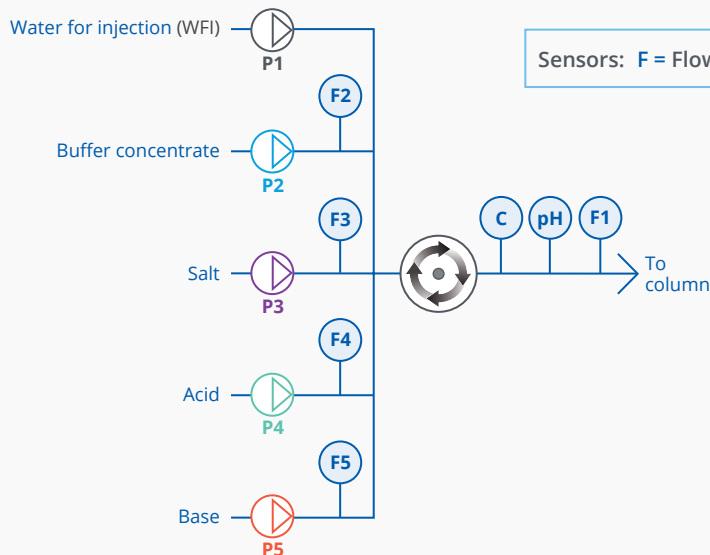

Conductivity and pH control / Flow control
 +/- 0.1 mS/cm or better
 +/- 0.1 pH or better



MOTIV 510	MOTIV 512	MOTIV 525	MOTIV 550
60 — 1000 L/h	120— 1200 L/h	Up to 2500 L/h	500 – 5000 L/h
Mobile console format	Space-saving skid format	Space-saving skid format	Space-saving skid format
Clinical scale manufacturing	Large scale manufacturing	Large scale manufacturing	Large scale manufacturing
Up to 20x dilution	Up to 20x dilution	Up to 20x dilution	Up to 20x dilution
1530mm x 1070mm x 1830mm	1530mm x 1070mm x 1830mm	1800mm x 762mm x 1854mm	Custom

Note: Dimensions are approximate. Customized systems for unique applications are also available.

Scalable Performance

MOTIV™ has been proven at flow rates up to 15,000 L/h, demonstrating broad capacity range and the ability to recover quickly from process disruption.



Figure 1. MOTIV holding the conductivity set point of saline solution to within ± 0.1 mS/cm at a total flow rate of 15,000 L/h. At 18 minutes, a 45-second hold interval was implemented to simulate a process disruption and the system pumps were stopped. After resuming operation, the system came back to the target set point within approximately one minute.

Minimal Recovery Time

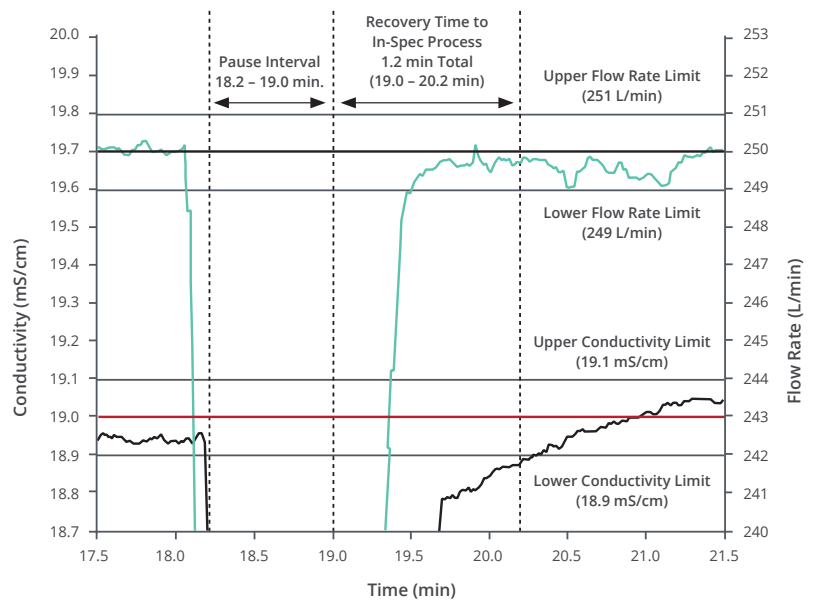

Figure 2. Expanded view of the pause interval and recovery region of Figure 1, highlighting the rapid recovery from process disruption.

Industry-Leading Buffer Capabilities

MOTIV™ systems have been used to produce the widest range of buffers of any comparable system on the market.

Compound	Molecular Formula	Molar Mass	Solubility in Water
Trisodium citrate	$\text{Na}_3\text{C}_6\text{H}_5\text{O}_7$	258.06 g/mol (anhydrous), 294.10 g/mol (dihydrate)	Pentahydrate form: 92 g/100 g H_2O (25 °C)
Pentetic acid (DTPA)	$\text{C}_{14}\text{H}_{23}\text{N}_3\text{O}_{10}$	393.35 g mol ⁻¹	<0.5 g/100 mL at 25 °C, 100 kPa
Tris	$\text{C}_4\text{H}_{11}\text{NO}_3$	121.14 g mol ⁻¹	<50 g/100 mL at 25 °C, 100 kPa
Sodium chloride	NaCl	58.44 g mol ⁻¹	359 g/L at 25 °C, 100 kPa
Trehalose	$\text{C}_{12}\text{H}_{22}\text{O}_{11}$ (anhydride)	342.30 g/mol (anhydrous)	68.9 g per 100 g (20 °C)
Monosodium phosphate	NaH_2PO_4	119.98 g/mol (anhydrous)	59.9 g/100 mL (0 °C)
		141.96 g/mol (anhydrous)	7.7 g/100 mL (20 °C)
Disodium phosphate	Na_2HPO_4	268.07 g/mol (heptahydrate)	11.8 g/100 mL (25 °C, heptahydrate)
		163.94 g mol ⁻¹ (anhydrous)	14.5 g/100 mL (25 °C)
Trisodium phosphate	$\text{Na}_3\text{O}_4\text{P}$	163.94 g mol ⁻¹ (anhydrous)	14.5 g/100 mL (25 °C)
Histidine	$\text{C}_6\text{H}_9\text{N}_3\text{O}_2$	155.15 g mol ⁻¹	4.19 g/100 g at 25 °C, 100 kPa
Sorbitol	$\text{C}_6\text{H}_{14}\text{O}_6$	182.17 g mol ⁻¹	2350 g/L at 25 °C, 100 kPa
Mannitol	$\text{C}_6\text{H}_{14}\text{O}_6$	182.17 g mol ⁻¹	216 g/L at 25 °C, 100 kPa
Sucrose	$\text{C}_{12}\text{H}_{22}\text{O}_{11}$	342.30 g/mol	2000 g/L (25 °C)

High Viscosity Buffers

MOTIV™ can also handle high viscosity fluids, such as glycerol. In minutes, a 20X dilution of 100% glycerol was successfully performed at room temperature on a **MOTIV 310** under both low flow (180 L/h) and high flow (1000 L/h) conditions.

5% Glycerol Prepared from 100% Glycerol Stock with Inline Buffer Formulation

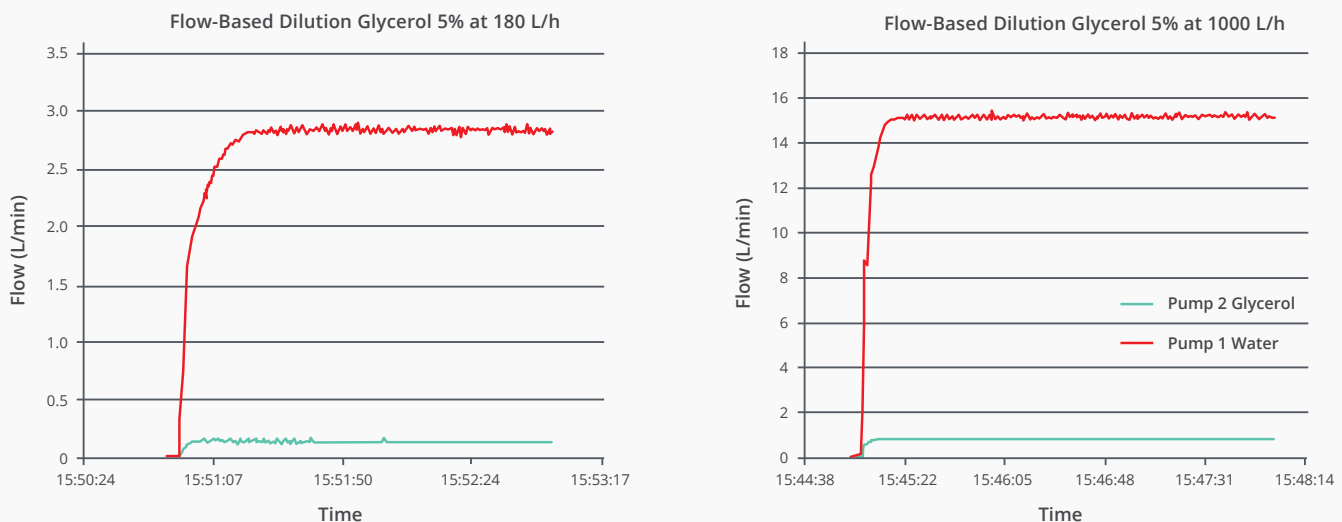
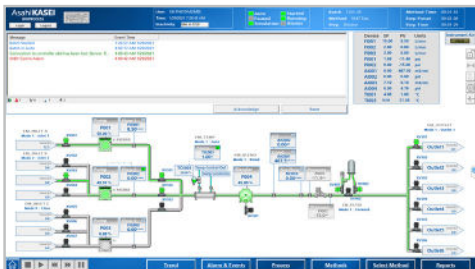

Figure 3. 100% glycerol at room temperature was successfully diluted by 20X at 180 and 1000 L/h.

Painless Precision – Automatically

Each MOTIV™ is outfitted with the latest in system control software – OCELOT™ – bringing intuitive configuration to all inline buffer formulation process steps. In a universally compatible format, OCELOT can integrate and/or interface with your plant-wide control system, allowing for far-reaching data collection and analysis.



Process control screen shows active two-inlet dilution (flow blend) with temperature control and inline filter

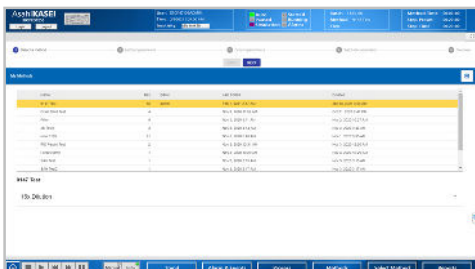

Batch initiation shows the method picker and preview of one-step method

Specialized

- » Each system is built to manage your critical process conditions
- » Settings, helper text and key process parameters can all be customized to create a unique user experience
- » Designed to be simple and straightforward

Seamless Integration

- » OPC-UA-ready architecture plugs into your existing DCS, OPC Server or Historian for batch monitoring and control
- » Browser-based to allow remote method configuration and review of batches, even while the system is in use

Flexible Yet Repeatable

- » Recipe configuration, report templates and trend display allows system operation
- » Default parameters, favorite steps, chart presets and report templates allow for easy repeat use
- » Point-of-use scale-up/scale-down through Control Parameter functionality

Continuous Processing

While MOTIV systems have, for the most part, been implemented to support batch processing, they can also be integrated to sustain continuous buffer supply.

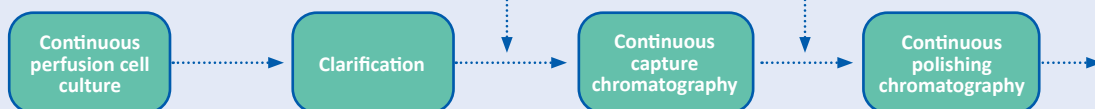

Figure 4. Create subroutines and stack recipe segments to produce multiple process buffers unattended and sequentially, just-in-time to feed continuous chromatography systems.

MOTIV® Configurable Options

All 3- and 5-pump systems are available with the following options:

- » Additional flow cell for pH and conductivity
- » Temperature control (heat exchanger)
- » 0.2 µm sterilizing grade outlet filter housing
- » Fillable bag weigh system



Achieve fast pH adjustment with our recirculation blender technology, reducing concentrate and WFI waste.

Standardized design with options for flexibility

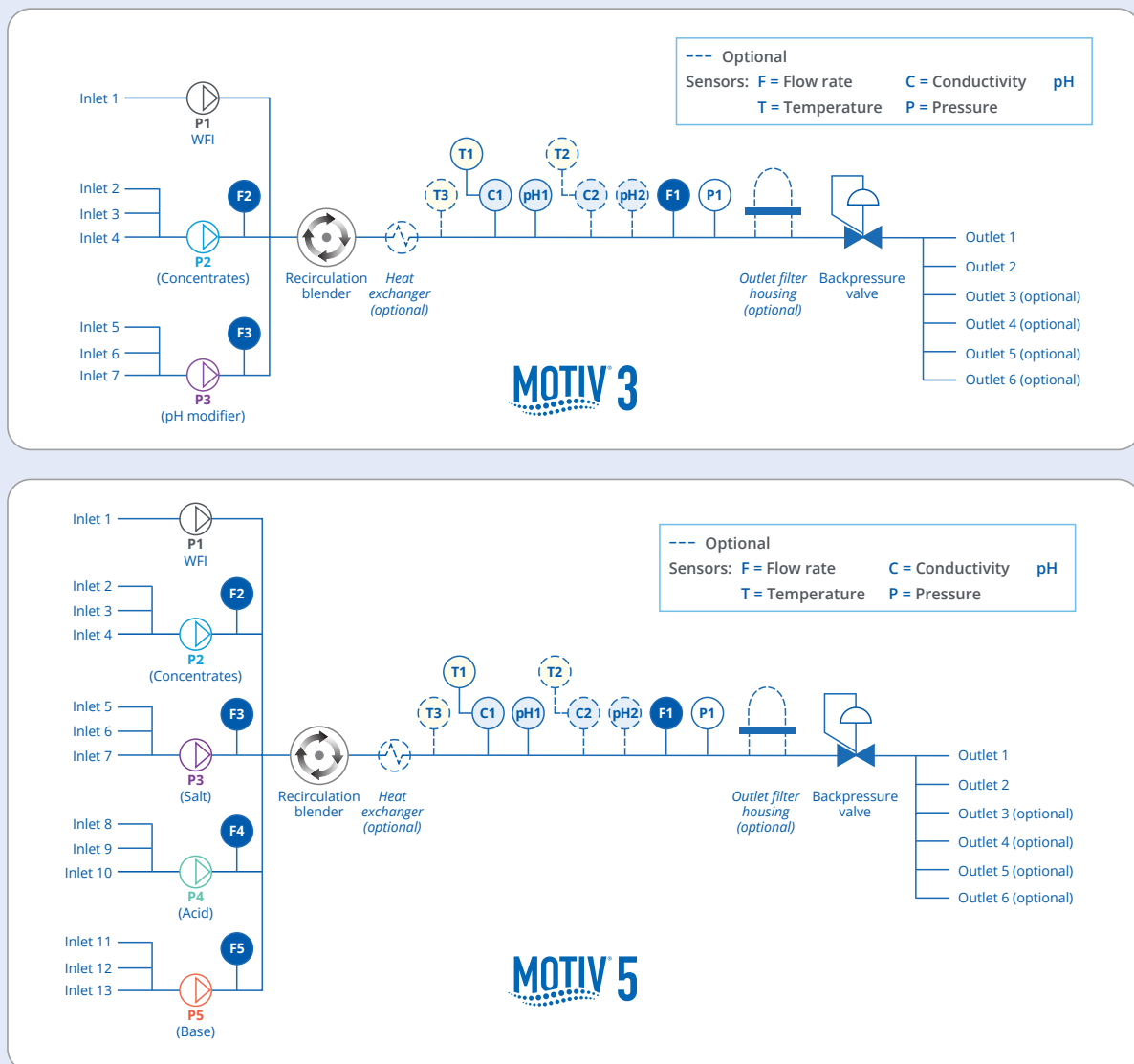

Figure 5. Flow schematics



Buffer Innovation In A Single-Use Package

The single-use extension of our award-winning line of MOTIV inline buffer formulation systems is built to produce complex buffers on-demand effectively and efficiently – all from one pump head, and without the need for CIP/SIP procedures between batches. The innovative design modulates flow through control valves while simultaneously integrating buffer solutions, providing proportional flow control, and mixing. As with all our MOTIV systems, OCELOT System Control ensures precise blends every time, controlled by pH and conductivity feedback or flow.



MOTIV SU
300 - 1200 L/h
Mobile console format
Clinical scale manufacturing
Up to 50X dilution
58.22" L x 32" W x 63.27" H

Note: Dimensions are approximate.
Customized systems for unique applications are also available.



[REQUEST A QUOTE >](#)

MOTIV[®] SU



powered by
OCELOT
SYSTEM CONTROL

Sensors: F = Flow Rate C = Conductivity pH

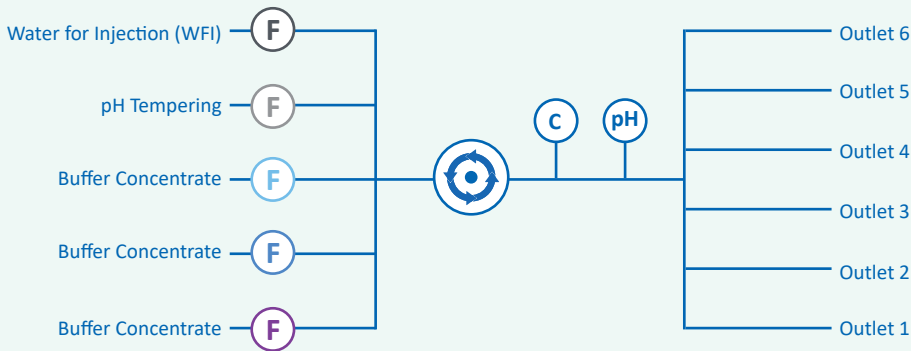

Achieve constant, controlled flow rates from all incoming process streams

+/- 0.5 mS/cm or better

+/- 0.2 pH or better

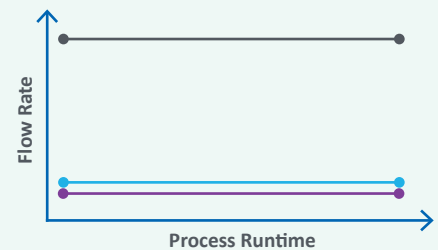

Contact Us

Asahi Kasei Bioprocess America, Inc.

Technical Client Services

+1 833-HLP-AKBA (457-2522)

TCS.support@ak-bio.com

www.ak-bio.com





Our Answer to the Non-Standard

If our standard 3- and 5-pump designs don't quite fit your unique situation, we can build you a system that will do exactly what you need:

- » Custom flow rate ranges
- » Specific materials of construction for corrosion resistance (e.g., AL6XN)
- » Additional pumps (>5 pump systems)
- » Additional inline monitors



AKB engineering experts can design innovative solutions truly built for you

powered by **OCELOT**
SYSTEM CONTROL



Our Expertise, Your Confidence

With deep experience installing and integrating inline buffer formulation systems in numerous facilities around the globe, our engineers bring a wealth of knowledge to ensure that your implementation is trouble-free.

Examples of common pitfalls	The Asahi Kasei Bioprocess Solution
Fluctuating pressures of incoming WFI feed	Forward pressure regulation valves
Fluctuating ΔP downstream of IBF System (buffer hold tank head; downstream filters, etc.)	Ensure backpressure regulation valve is upstream of divert valve Size pumps for the discharge pressure at the buffer hold point, not at the pump discharge
Chemical compatibility concerns with concentrates	Polymeric lines, other alloys such as AL6XN, Hastelloy
Fluctuating temperatures	Shell-and-tube, tube-in-tube, or U-tube heat exchangers

Aftermarket Services

Technical Support Network

A reliable technical support network is available throughout North and South America, Europe and Asia.

Warranty

We offer an extendable 1-year warranty, service contracts and a personalized level of service for peace of mind and timely support when you need it.

[REQUEST A QUOTE >](#)

Technical Client Services

Technical Client Services (TCS), is a customer-centric interface to our product and science experts. Our TCS team will guide your process and engineering needs as your personal liaison for inquiries.

Contact us to learn more about how TCS can support your virus filtration and downstream processing equipment needs.

Asahi Kasei Bioprocess America, Inc.

Technical Client Services

+1 833-HLP-AKBA (457-2522)

TCS.support@ak-bio.com

www.ak-bio.com

Global Offices

North and South America

Glenview, IL, USA
Tel: +1-833-457-2522
Fax: +1-847-556-9701

Email: info.us@ak-bio.com

Europe

Cologne, Germany
Tel: +49-221-995007-59
Fax: +49-221-9950077-59

Email: info.eu@ak-bio.com

India and Southeast Asia

Mumbai, India
Tel: +91-22-6710-3962
Fax: +91-22-6710-3979

Email: info.jp@ak-bio.com

East Asia and Oceania

Glenview, IL, USA
Tel: +1-833-457-2522
Fax: +1-847-556-9701

Email: info.jp@ak-bio.com

China

Shanghai, China
Tel: +86-(0)21-6391-6111
Fax: +86-(0)21-6391-6686

Email: info.jp@ak-bio.com